

Microirrigation Design Considerations

Robert Burney and Edward W. Hellman

Irrigation can be vital to the health and productivity of vineyards in many grape-growing areas of the world, including drier areas in Oregon. Many western Oregon sites receive adequate rainfall and have deep soils with good water-holding capacity. Irrigation is not essential to maintaining a vineyard on such favorable sites, but it can provide several benefits to perhaps justify the cost; see Chapter 19 for a discussion of the potential benefits of irrigation and economic considerations.

The purpose of this chapter is to provide information about the major components of vineyard irrigation systems and their use. The emphasis is more on design considerations than actual construction and maintenance. You will not be an irrigation expert after reading this chapter, but you should be a more aware consumer capable of asking good questions and making informed choices. Because of the complexity of irrigation systems and the number of variables involved, consultation with an irrigation design professional is recommended. Additional information can be found in Schwankl et al. (1998).

Microirrigation has become the standard water delivery method for vineyards, primarily utilizing drip emitters; microsprinklers may be appropriate for some situations. Microirrigation is the most water- and power-efficient irrigation method available. Recent developments extend this efficiency to sprinkler frost protection systems. Lower flows allow either smaller system sizes or more vine area to be watered with a given water supply. Still, the installed cost of the water distribution portion of an irrigation system can easily reach or exceed \$2.00 per vine. Water source development costs are widely variable because they depend on the type of water source, power requirements and source, and pumping and filtration requirements. Sprinkler frost protection demands a larger water supply and more power and would be a major addition to what is needed for a drip irrigation system alone. The development cost of a simple, modest water supply for a drip-irrigated vineyard of several to a few dozen acres could be between \$8,000 to \$20,000. Costs for larger vineyards, or to add frost protection capability, can range several times higher. Determine whether the benefit to your vineyard is worth the initial and ongoing cost and labor. Keep in mind that costs continue beyond the installation; inspection, maintenance, and operation of the system will be a significant annual expense.

Preliminary Considerations

Water Supply

There are a few essential preliminary factors to investigate prior to developing an irrigation system. First, adequate water supplies may not be available in some areas. In Oregon, water belongs to the public, not the landowner. Contact the local watermaster to find out about local water rights, priorities, and conditions. Possessing a water right is not a guarantee of availability.

There may be little or no surface water legally available when it is needed most, even if it is flowing through the vineyard property. New agricultural irrigation is essentially prohibited in a few designated areas of Oregon because of low water availability. Collection and storage of seasonal surface runoff and subsurface drainage are, however, allowed. Damming a perennial stream is not permitted.

The water source should be evaluated for sufficient flow and volume during critical times of the growing season. Streams, ponds, and wells often decline during periods of drought. A brief well test is no guarantee of sustained irrigation capacity in late summer. Find out about the water source before spending thousands of dollars on an irrigation system.

Irrigation water requirements are highly variable and site dependent. Local climatic factors of importance are quantity and seasonal distribution of rainfall, temperature, humidity, and wind. Other site-specific factors include soil water-holding capacity, soil depth, vine planting density and age, and cover crop.

Block Layout and System Sizing

Managing your vines for uniformity and quality is an important goal. Most sites have some variation in soil characteristics, topography, and perhaps even climate. Thus all but the smallest sites will probably be subdivided into blocks to achieve both uniformity and

practicality. The irrigation system should likewise serve and promote these twin goals.

There are two common mistakes in designing irrigation: not allowing for potential expansion, and not including a margin of extra capacity. A system that is designed to barely meet criteria under-performs in practice. There are always changes, and small errors are sometimes made in design or installation of a system. Additionally, wear and deterioration develop over time. “Little” vine additions here and there may significantly increase demand on the system. So it is always prudent to build in a margin of extra capacity beyond today’s peak demand.

Ideally, irrigation system design proceeds concurrently with vineyard design. Coordinated planning enables blocks to be sized to match their irrigation demand with the capability of both the water source and the delivery and distribution systems. Demand primarily means flow (gallons per minute), and maximum flow is often a system’s limiting factor. Blocks may have to be sized to match the well or pump output, rather than vice-versa. Developing additional water sources may be the only solution to providing the required water in a reasonable time frame.

System planning must calculate the water demands of each block in terms of both volume of water applied and the time required to distribute it. Relevant factors are the number of vines, emitter size and number per vine, volume applied per plant, and scheduling.

There is no fixed amount of water required for irrigation. Optimally, an irrigation system would be capable of watering one-third of the vineyard at a time. This capacity balances cost and size versus performance and convenience, responding reasonably quickly to extreme conditions. Individual circumstances may warrant a different capability. Make sure that the irrigation capability is sufficient in a heat wave or drought. Capacity less than one-fourth or one-fifth of the whole vineyard may compel some reduction of the area to be irrigated.

What does this mean in practice? Most commonly, vines each have one half-gallon emitter (for vine spacing of 5 feet or less) or two half-gallon emitters (for spacing of 5 feet or more). It must be noted that “gallon” emitters actually are sized in liters. Thus a half-gallon emitter delivers 2 liters, or 0.53 gallons, per hour, which is nearly 6% more water than the “half-gallon” nomenclature implies. Actual delivery rate should always be used in calculations. Convert liters to gallons by dividing by 3.78.

We use a hypothetical vineyard for several calculations in this chapter. Our example is an 18-acre vineyard divided into three 6-acre blocks for irrigation scheduling. Vine density is 1,245 vines per acre (5- by 7-foot spacing), with one “half-gallon” emitter per

vine. Thus, one block requires flow of 3,960 gallons per hour, or 66 gallons per minute.

$$\begin{aligned} &6 \text{ acres} \times 1,245 \text{ (vines/acre)} \times 0.53 \text{ (gallons per hour/vine)} \\ &\times (1 \text{ hour}/60 \text{ minutes}) = 66 \text{ gallons per minute} \end{aligned}$$

If less flow than required by this design is available from our water source, there are a few modifications that can be made to reduce the flow needed. The vineyard could be broken up into more blocks of smaller size, which increases materials and labor expense. Our example vineyard is already using the smallest emitter size and only one emitter per vine, so no reduction of emitters is feasible. If available volume or prolonged scheduling is limiting, that may force a choice not to irrigate some portions of the vineyard. Exclude perhaps a less important block or one for which irrigation is less needed. Determine how long it would take to get through a complete irrigation cycle. Blocks with different characteristics or irrigation strategies may need different schedules. Work out schedules on paper to ensure real-time feasibility. Complicated irrigation schedules are much easier to manage with an automated controller.

Irrigation System Elements

The major elements of a drip irrigation system are illustrated in Figure 1. Note that a specific system may have a different sequence or not utilize all of the components shown in the diagram. We discuss these components individually, beginning with the water source and moving downstream.

Water Source

It is advantageous to have access to a perennial stream, spring, or lake. More often, however, one or more wells or ponds must be developed. Determine if multiple sources are truly independent or instead drawing from the same primary source. Water quality must be analyzed, regardless of the source and preferably during the season of use, to determine the required filtration treatment. The type and amount of contamination determines how elaborate the filtration and treatment must be.

Surface Water. The solid contaminant load of surface water is apparent. Algae and water plants are especially prevalent in slow or still water in summer. Ponds often require chemical treatment or pre-filtering to make final filtering manageable. If a pond has no outflow during the irrigation season, algae and aquatic plants can be controlled with chemicals. Most surface water warrants an automatic backflushing filter.

Pond construction and maintenance greatly influence aquatic plant growth. Making the sides steep, clearing plants off the banks, and keeping out

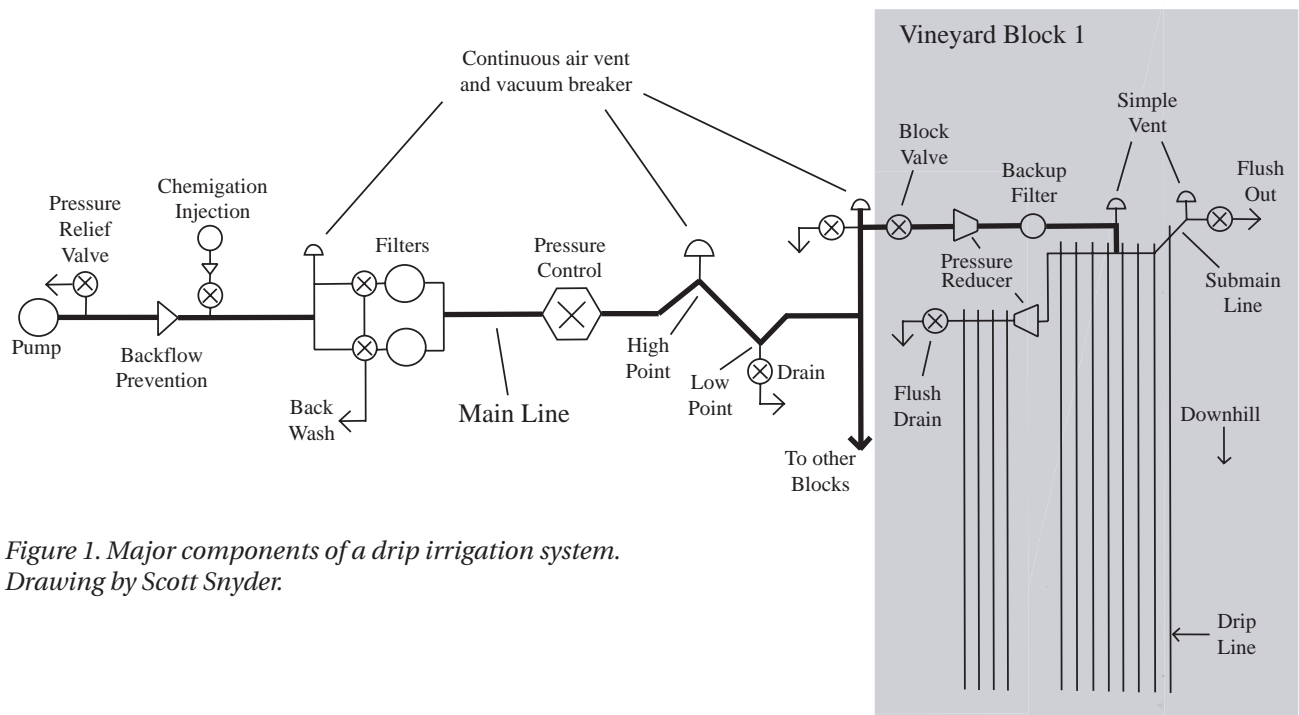

Figure 1. Major components of a drip irrigation system.
Drawing by Scott Snyder.

leaves and debris keep growth down and thus minimize filtration load.

If water inflow is much less than irrigation output and losses, a pond must be of adequate size to accumulate enough water beforehand to complete an irrigation season. Remember to factor in evaporation loss when determining the required size of the pond; this can be estimated from "Pan Evaporation" data available from local weather stations. To increase volume, make the pond deeper in preference to wider. Some ponds leak enough to require sealing with bentonite or a plastic liner material.

If you are developing a new pond, it is a good idea to install a pipe in the bottom to supply the pump and allow draining. With proper fill and compaction, there is no leakage along the pipe. Configure the inlet so that water is not drawn off the very bottom. Put valves on the outside end for draining and for isolating the pump.

Ground Water. Water from wells and springs that is not influenced by surface water is called *ground water*. Since it is not visible, one cannot be sure how steady and reliable it will be. A storage tank or pond is necessary if steady water output is needed but the ground water source is intermittent. An intermittent source is indicated by the well pumping dry and requiring several minutes to refill. Electronic motor-load sensing is essential to signal a dry well and protect the pump. A totaling flow meter or an hour meter on the protected motor gives an indication of pumped volume.

If flow just has to be smoothed out or supplemented over a day or so, a tank may suffice. If average flow from the source is too low, the required tank size becomes impractical. In that case, only a pond can accumulate enough water for extended irrigation.

Ground water is intrinsically low in organic matter. It may be very pure and clean, or carry some amount of both dissolved and solid inorganic matter. Wells may pull in enough particulates to need a centrifugal separator or automated back-flushing filter.

Dissolved minerals that precipitate and clog lines and emitters can be a major problem. They must be treated to either stay in solution until through the system or come out of solution before going into distribution. The hardness minerals calcium and magnesium can be kept in solution with acid or proprietary chemical injection into the water flow. Low levels of iron or manganese can be treated by the same method. Moderate to high levels are difficult and, fortunately, rare. They must be oxidized, precipitated, and settled or filtered out before distribution. Media filtration is best in this situation. Aeration and settling is a low-tech approach for moderate concentrations. It requires a large tank or basin and second pump for filtration and distribution.

Very high iron/manganese concentrations, or circumstances with space constraints, are best managed by standard potable water treatment. This involves injection of a strong oxidizer, followed by catalysis and filtration with specialized manganese greensand media filters. Consult an industrial or municipal water treatment specialist if mineral

problems are serious. When chemicals are used to treat water, the upstream source must be isolated from all treatment materials by the proper placement and use of backflow prevention.

Whether treatment is simple or complex, the essential point is that the expensive investment in thousands of emitters must be preserved with clean water. Filtration is addressed separately below.

Pump Suction

The path water takes to the pump inlet is the first critical element of the system, especially if it is located above the level of the water source. This path, the *suction*, has requirements for pipe size and limitations on elevation. Pumps create only a fraction of atmospheric pressure as suction. Therefore, water must arrive at the inlet with a certain amount of pressure, called the net *positive suction head*. If the pump is positioned too high (more than 20–23 feet above the water) or the suction line is too small or leaks, it will work poorly or not at all. Avoid creating a high spot in the suction line, which restricts flow as it fills with air released from the water in the partial vacuum of the line.

An underwater (“flooded suction”) pump positioned at the base of the storage tank or pond dam simplifies water intake by the pump. If the suction is not flooded, there must be a way to prime the pump. Non-flooded suctions generally have a foot valve to maintain prime. A foot valve is simply a check valve at the inlet end of the suction, with a coarse screen. Flooded suctions require a manual valve so the system can be isolated for servicing. An inline check valve is necessary, and it can be located on either side of the pump.

Pumps

Most irrigation systems are not gravity-fed, so one or more pumps are needed. The nature of the water source and the required flow and pressure determine the size and configuration of the pump. Centrifugal pumps in various configurations are used most commonly for irrigation.

Power source. Current options for the pump power source include utility or solar electricity or a gasoline, propane, or diesel engine. Selection of the power source depends on availability and cost, the nature of the irrigation cycles, and personal preference. For example, engine power is not well suited for a site that is unattended for long periods or uses an automated irrigation schedule.

Bringing utility or solar electric power to a site can be prohibitively expensive. Be sure to investigate utility rate charges for agricultural use, and particularly the “standby” charges that accrue for all the

months that power use is low. Standby charges can be substantial, exceeding the actual energy use costs.

Solar power is another option for remote areas, but it is limited largely by the cost per unit of power. Fuel cells show good potential for practical and affordable power within a few years. They convert fuel and oxygen directly and efficiently into electric power, without combustion.

Engine-powered pumps are often the best choice, especially for higher horsepower applications. The larger flow of sprinkler frost protection generally requires engine power. Select an engine that fulfills system needs when running at no more than 75% of rated power, to ensure longevity of the engine. Also, be sure the rating factors include operating altitude and peripherals such as the fan, water pump, and alternator. The drawbacks of engine power include noise and requirements for attendance, refueling, and maintenance.

Pump Size. The appropriate pump size is determined from the required flow and pressure necessary to deliver water to the system. *Total dynamic head* is the cumulative term for the pressure needed from the pump and is described in trade jargon as “feet of head.” Height is used as a pressure unit because irrigation system design is always working with the height difference between the water source and the delivery point. This is called *static head*, the pressure exerted strictly by the height of water above any given point. Whether the water is in a half-inch pipe or a lake does not matter. A water depth of 2.3 feet exerts pressure of 1 psi (pounds per square inch), thus “1 foot of head” equals 0.43 psi. Convert to consistent pressure units as needed, but conceptually they are the same.

Ignoring tiny, complicated factors, total dynamic head is the sum of static head, friction loss, and net operating pressure. In addition to static head, water moving through the system loses power to friction, which is manifested as pressure loss. Finally, the system needs net operating pressure differential through every step. This is a way of saying that pressure difference and friction both affect flow. Zero pressure difference results in zero flow. Selection of the pump should include an additional reserve margin of pressure to allow for error and degradation.

Determining Static Head and Friction Loss. Delivering a specific flow and pressure to a specific place requires information about the static head and friction loss to be overcome. Static head is determined by measuring the elevation change between the water source (including below ground level in a well) and the delivery point in the vineyard. Accurate determination of elevation can be a challenge. Topographic maps, altimeters, stereoscopic photography, and

direct static pressure measurement are some of the tools available for measuring elevation. Educated guesswork and simple geometry may suffice in nearly flat situations.

Here is one method to directly measure static head on a hillside. Get a 1,000-foot roll of quarter-inch “spaghetti tubing” and some fittings from a drip irrigation supplier. Attach a valve and female garden hose connector to one end. Fill the roll completely with water and close off the other end with a pressure gauge, which becomes the bottom end. Keep the valve closed until the tube is laid out from the high point to the low point. Open the valve at the high point and read static head off of the pressure gauge at the low point. Coils and the lie of the tubing between the two ends do not affect the reading as long as the tube is completely full all the way. Again, each 1 psi indicates 2.3 feet of elevation change.

Elevation determinations from a USGS topographic map are inexact. Common, low-price altimeters give mediocre results. A surveying altimeter or other surveying techniques can be accurate, but their cost is higher and may only be appropriate for large or complicated sites. However determined, elevation change in feet is the same as static head in feet.

Calculating friction loss uses a complicated equation involving the pipe size and flow rate. Using reference tables or a special slide rule simplifies the process of determining unit friction loss with the equation. Friction loss is usually expressed as loss per 100 feet of pipe. Pipe friction loss is simply the multiplied product of the length of the pipeline and the unit friction loss. Additional losses from elbows and fittings are often approximated as 5–10% of the calculated pipe friction. Understand that the pipe size for calculation is the inside diameter, known from the nominal size and type (schedule 40, class 200, etc.). Remember to convert different pressure units to one consistent unit.

Velocity is a more tangible way to visualize water flow, although less important than cumulative friction. A rule of thumb is to keep velocity in the pipe under 5 feet per second to keep the total friction low. In practice, velocities are mostly well below 5 feet per second in long level or uphill runs. Major components like filters and special control valves generally have friction loss versus flow data available, along with other design data.

The operating pressure at the block depends on losses through the valve station, topography, and type of emitters. For a typical block irrigated downhill, specify at least 15 psi at every emitter. Total dynamic head is then calculated by summing the static head, 105% of friction in the suction and main line, friction across the filter, friction in the block valve assembly, and operating pressure needed at the block. The calculation of total dynamic head for one 6-acre block in our example is provided in Table 1.

Pump Selection. Pumps are selected primarily on the basis of the horsepower (hp) needed to deliver the necessary flow in gallons per minute at the required pressure (total dynamic head). Continuing our example, the 6-acre block requires a flow of 66 gallons per minute. The required pump horsepower can be estimated with the figures for flow and total dynamic head plugged into the general equation below:

$$\text{Flow} = 66 \text{ (gallons/min)} \times \text{Pressure} = 177 \text{ (feet of head)} \\ \frac{\quad}{3,960 \text{ (unit cancellation factor)} \times \text{Pump efficiency} = 0.60} = 4.9 \text{ hp}$$

Pump efficiency is commonly about 60% for a medium or larger pump near its optimum performance. Smaller pumps and off-peak operation can be substantially less efficient. It is best to use actual performance data for prospective pumps, especially if pressure or flow will vary. See Figure 2 for an example of a pump performance curve that is appropriate for our example vineyard block. Notice that efficiency is highest around the middle of the pump performance range. Try to match high efficiency in the pump to the most common operating conditions of most blocks.

Select an appropriate pump with the approximate horsepower needed. Compare the flow and total dynamic head for each block with pump performance curves to select a pump that can best meet or exceed these demands. In other words, the point where the demanded head and flow meet on the graph, for each block, must be on or below the curve of the pump performance. How much below is the size of the reserve margin. Some pumps are better at maintaining pressure over a range of flow, so choose a pump with a flatter curve if your block size varies more than elevation. Other pumps are better at maintaining flow over a range of pressure; choose a pump with a steeper curve for larger elevation changes or fluctuating water level in a well.

Table 1. Calculation of Total Dynamic Head

Static Head		Friction Loss			Operating Pressure	Total Dynamic Head
Pumping Depth	To top of Block	Filter	Pipe (105%)	Valve station	1.5 psi x 2.3 ft/psi	
60 ft	40 ft	19 ft	15 ft	8 ft	35 ft	177 ft

Pump Arrangement. The pump can be run continuously and directly into the distribution system if the combination of flow and pressure needed for each block is fairly close to the output of the pump. Frequently however, there is at least one vineyard block that needs much less than full output. Continuous pumping to a small demand wastes power and could overheat the pump or overpressure the system. The latter problem could be handled with a pressure-reducing valve to maintain needed flow at a safe pressure. The wasted power might warrant a more complicated strategy, either cycling the pump off and on (with conventional pressure switch and tanks) or slowing it down (with a variable frequency drive on a larger pump). Larger pumps are awkward at small, intermittent tasks like supplying domestic water. Another well or a storage tank filled by the irrigation pump may meet such needs best. On the other hand, a small source filling a storage tank is a real time saver for vineyard spraying.

Consider using a second pump in series to get water to upper blocks if the elevation range of the vineyard is large. This could be mandatory if the total dynamic head is greater than the safe working pressure of the system components. The maximum operating pressure of many filters and other components typically ranges from 80 to 150 psi. Locating the filtration much higher than the pump would also reduce the pressure

at the filter. Be careful about matching flow capabilities of the two pumps in such a situation, and consider the effect of filter backflushing. Failsafe controls to stop both pumps in case of interrupted flow must be included.

Likewise, two pumps in parallel might be better for a wide range of block size. Be careful about matching output pressures with parallel pumps, or one may “shut off” (overwhelm and stop) the flow of the other. Equally important is being sure the filter operates properly with the different flows. Parallel pumps may be run directly to the system or with a pressure control setup. The latter uses pressure tanks and a lead pressure switch on the first pump and a lag pressure switch to start the second pump at slightly lower pressure.

Electronic Controllers

It may be convenient or necessary to have automated controls for your irrigation system. Electrically powered systems can be set up with automatic operation fairly easily with programmable electronic timers. Choose one with enough features and stations to cover present and future needs. Also be sure the maximum run time is enough for your planned drip cycles. System equipment such as the water pump, booster pump, chemical pump, and backwash timer can be run in conjunction with the block control valves.

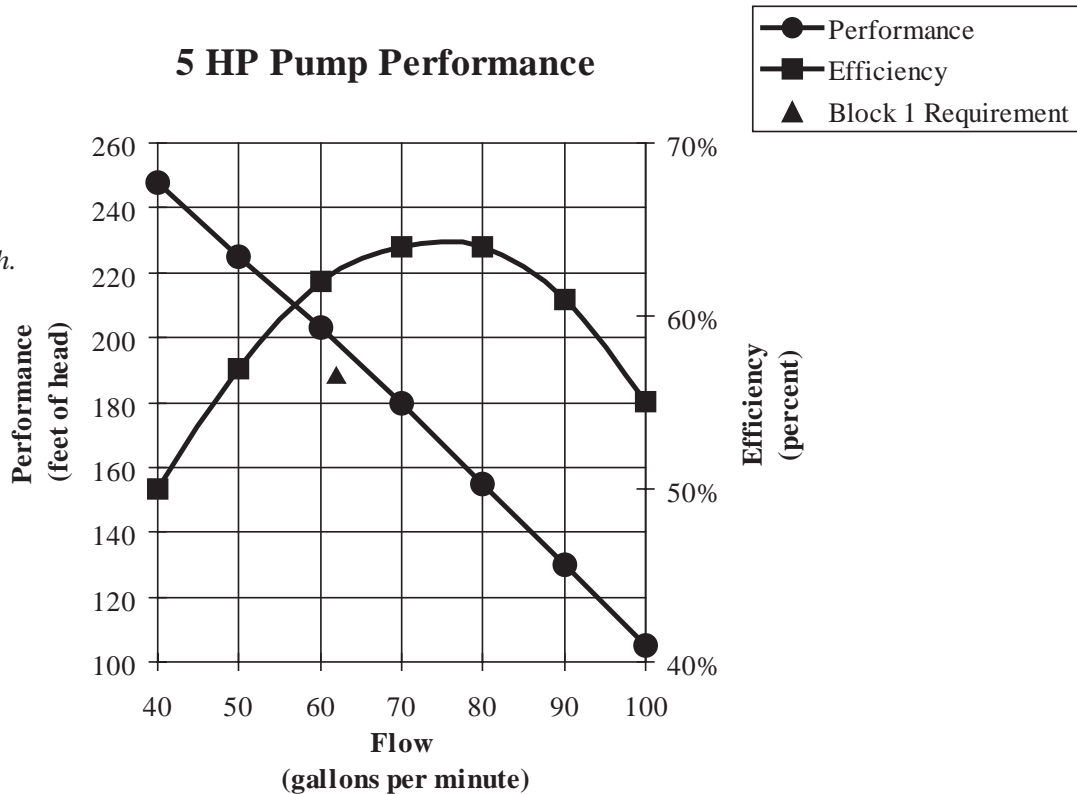

Figure 2. Pump performance graph.

Timers use a tiny amount of power, but it is not a good idea to take it from the pump's circuit. Use a different circuit, preferably one dedicated to the timer. The timer's electronics are sensitive to voltage spikes and transients like those created by motors. Aside from hardware damage by major surges, "dirty power" can scramble your programming entries in the timer memory. A lot is riding on proper functioning of the system, so provide the necessary protection. Modest surge protectors, either hard-wired or plug-in, are adequate.

Valves, Venting, and Other Devices

A pressure relief valve is prudent in any pumping situation except when discharging into an open body of water such as a pond. The valve must always be available to the pump and sized to pass enough water. If normal flow is blocked, the relief valve protects the pump and nearby pipe from damage by overheating and overpressure. The relief valve can be spring-loaded or a "sustaining and relief" diaphragm valve. The opening pressure is above the highest operating pressure and several pounds per square inch below the shut off head pressure of the pump. The regulated diaphragm valve is preferable when the relief pressure is only a little above operating pressure. Downhill runs may need pressure-reducing valves to keep pressure within safe levels. Pressure-sustaining valves are less commonly used, but sometimes they are vital in maintaining upstream pressure. Low points need manual valves or automatic drains to protect pipes from freezing. Domestic water must be isolated from agricultural water. This is done with an "RP," a reduced pressure principle double check valve assembly. All water sources must be protected from backflow of injected chemicals. Water sources strictly for irrigation may be protected from backflow by the use of a "chemigation check valve." Simple check valves are used wherever reverse flow has to be stopped.

Fertilizers and other soluble agricultural chemicals can be delivered through a drip irrigation system. This topic is covered well in Trimmer et al. (1992).

Every high point in the line, from the pump to the filter and from the filter to the ends of the main line, needs a continuous-acting air vent/vacuum breaker. These allow air to escape even under pressure, and air to enter into a vacuum. Venting air steadily during filling reduces water "hammer" (momentum), which occurs with a sudden release of trapped air. Releasing air also lets water flow through the full cross section of the pipe. Breaking vacuum lets the system drain well and prevents collapse of thin pipe walls.

One item that is often recommended, although it is optional, is a flow meter. This meter measures actual

flow, which is useful for comparison to system design values and to indicate required maintenance.

Filtration

Every microirrigation system must have at least one filter, no matter how clean the water seems to be. Too much is invested in thousands of emitters to risk getting them clogged. There is no perfect and trouble-free filter, but in a given situation some are less suitable than others.

Different degrees of filtration can be matched to the application; 200 mesh (74 micron) or 80 micron filtration is fairly standard for drip systems. Practically all the filter types are available in a range of sizes or assemblies for flows up to thousands of gallons per minute. Pressure drop across the filter increases as debris builds up, so it must be monitored to maintain full flow. Monitor pressure by installing gauges before and after the filter or a differential pressure gauge that compares the two sides. Systems may need to include valves to enable draining and maintenance of the filter.

There are a variety of different filter types for different needs:

Simple Screen and Disc. Simple screen filters have a fine mesh stainless steel or fabric element, usually cylindrical. Various clever additions to the basic element extend the run time between disassembled cleanings. These include swirling inlet water or increasing velocity with an insert to move debris to a flush valve. Another option for coarser debris is a cranked internal brush and flush valve.

Simple disc filters use a tight stack of flat plastic rings with a molded pattern of ridges. The stacked patterns criss-cross to filter through more depth than a screen filter. Discs are better than screens for retaining algae. The practical difference between these two types of simple filter is less dramatic than sometimes proclaimed.

Screen and disc filters need shutdown and disassembly for periodic cleaning. They are most suitable for manually operated systems, and for water with relatively small amounts of inorganic contaminants, such as clean ground water. Prudent system designs incorporate simple filters at block valve stations as last-chance backup filtration.

Backflushing Filter. Backflushing filters reverse clean water back through the filter element to remove contaminants. They are usually set up to clean themselves automatically, which is convenient for heavier contaminant loads and automated irrigation.

There is a minimum flow and pressure needed for backflushing. If there is not enough flow capacity for backwashing along with irrigating, the irrigation must be briefly stopped or reduced. This can be done with

a pressure-sustaining valve positioned downstream from the filter. If continuous flow is critical, such as for frost protection or into a secondary pump, use a larger number of smaller filter units for a reduced backflow requirement.

Disposing of backwash water may influence selection of the type of filter. For example, media filters put out a lot more backwash than other filters. Backwash water is typically put back into surface water, away from the suction intake, or into a drainage. Backwash recycling units are available to filter out solids for disposal and pump water back to the system.

Media Filter. Media filters are small tanks in an array of two or more. They filter through a thick layer of sand or similar “media,” so they are big and heavy for a given capacity. Media filters are more sensitive to variable flows and have the most extensive setup and maintenance procedures to be followed. The media must be checked and replaced periodically because the sharp edges degrade and media slowly gets flushed out.

The filter bed captures debris in three dimensions, collecting it up to a few inches deep and thus having a relatively large holding capacity. Each tank is backflushed with filtered water flowing up through the sand bed and out a backflush valve. Filtered water comes from the other tank(s) in the array. Backflush flow fluidizes (fluffs up) the media a few inches to thoroughly release debris. Media filters are often used to remove the organic materials from ponds and surface water. They are less suited for ground water with dense, coarse particulates but are the best choice for removing chemically precipitated matter.

Disc Filter. Another popular type of automatic backflushing filter uses two or more disc filter stacks. Flushing is similar to media filters. Disc filters with automatic backflush give fair to good performance with both organic and inorganic debris. They are compact compared to media filters, especially for higher flow configurations, and backwash volume is also lower.

Rotating Point of Suction. The other major type of backflushing filter uses a cylindrical screen filter element with a rotating apparatus that works like a vacuum cleaner. Dirt collects on the inside of the cylinder, and a central tube with slotted nozzles is positioned close to the screen. This is the “vacuum cleaner.” To backflush, the flush valve opens this tube to atmosphere. Water moving inward through the filter and into the nozzles pulls the dirt away from the screen and out of the filter. A hand crank, electric motor, or water is used to rotate the scanner so the entire inside surface is cleaned.

Centrifugal Separators

Any filter can become caked over with debris when water contains a large percentage of inorganic particles. Centrifugal separators are used prior to filtration to separate out particles more dense than water. Water enters tangentially at the upper end of the separator, through a small inlet pipe at rather high speed. Water swirls around and downwards in a vortex, then up along the central axis. The centrifugal action slings heavier particles to the wall; gravity slides them down the wall and into a lower chamber. From there, they are flushed out periodically through a manual or automatic ball valve, with the separator under pressure.

Small and less dense debris, including organic matter, pass right through the separator. Water goes through regular filtration after the separator. It is important to operate separators within their designed range of flow to get good separation. Smooth incoming flow is best, so the inlet should be straight for a length of several pipe diameters. For the same reason, constrictions such as a throttle or modulating valve need to be downstream of the separator.

Water Delivery and Distribution

Main line. Preliminary planning and early work should result in a final version of the water supply, pump, and filter by the time an irrigated vineyard is laid out. The job of the main line is to deliver clean water efficiently and economically from the pump and filter to the vineyard blocks, at needed flow and pressure. It is the piping that “stays charged,” or full of water.

The general idea for routing the main line is to keep it reasonably short and direct to both existing and future vineyard blocks yet accessible during and after construction. Minimize crossing under rows and favor avenues over row middles. The main line should go to or near the uphill end of each irrigation block to minimize uphill flow in submain lines and drip tubing. The main should deliver at least 5–10 psi over the desired pressure to each block, to counteract losses in the valve assembly. The location and depth of all piping should be safe from driven posts, earth movement, tractors, and underground work. Use fine, loose material for backfill next to pipe, and keep rocks away. Imported fill may be needed around pipe in rocky sites. Air vents at high points and drains at low points improve performance and protect piping.

The valve assembly that makes the transition from main line to submain at each block location may be above ground or in a box below ground level. The valve station may include a flushing valve, air vent, pressure gauge, or drain valve in terminating the main line. Additional components that are part of the block are mentioned below. The assembly is generally in a row

close to the upper end of a block and should be located either between vines or just beyond the end post. These locations make it safer from tractors and implements yet accessible from the avenue. Some blocks, notably those with irregular shapes or topography, may best be served with water delivery to somewhere in the middle of the block.

Note that the main line usually needs to terminate at an exact point in the vineyard layout. That means that trenching and pipe assembly are best done after vineyard layout is final and before driving trellis posts or planting. Installation is much more prone to error and change if done before vineyard layout stops evolving.

Limited curvature of trenches is acceptable for PVC pipe, as long as joints have cured for a few hours. The safe amount of bending decreases quickly with increasing pipe size. Common fittings are 45° and 90° elbows; other angles are accommodated by closely pairing two fittings (45°, 90°, or tee) in a combination to line up with the intersection. Draw an “as-built” map after installation so the exact location of pipe is known and recorded. Repairs or modifications are inevitable, so you don’t want to have to guess where the pipe lies in the future.

Submains. The submain begins with the manual or automatic valve to the block. Submains are the part of the irrigation system that controls and distributes water to each block and the drip tubes in each row. Other features of the submain may include backup filtration, vacuum breaking at high point, flushing at ends, and pressure reduction to that desired for the emitters. Pressure reduction may be incorporated in the supply valve or in a separate pressure-reducing valve. The latter may be located with the rest of the valve station or with the distribution piping and risers if the latter are not adjacent.

A typical operating pressure for emitters is 20 psi, although steep blocks might start at 10–15 psi at the top of the block so that the pressure is not too high lower down. Elevation differences over 70–80 feet within a block can require multiple pressure-reducing valves for subsections, individual rows, or even within each row. The distribution piping of submains sends water to, or near, the high point of each row of the block. The concept is to deliver water so flow goes downhill, counteracting pipe friction. The submain pipe is on a perpendicular or diagonal across vineyard rows, either between vine locations within the block or just outside the end post position.

Submain pipe size is determined by counting the number of emitters and calculating flow in each row. Row flows are added up from the ends back to the connection to the valve station, and pipe is sized accordingly. Normally, submain pipe size is decreased

as flow drops to an appropriate rate in serving fewer remaining rows. Pipe size reductions should, however, be limited to just three or four sizes (i.e., 3 inch, 2 1/2 inch, 2 inch, 1 1/2 inch) so that flushing velocity is effective in the largest size.

The ends of the submain need a flushing valve but do not need the pressure relief valve often included in older installations. One or more vacuum breakers (simple air vents) at high points aids draining after shutdown and prevents pipe collapse. A small area of isolated or “point” rows is often just connected to a couple of adjacent rows to save a long run of trenching and pipe.

For each row, a riser comes from a tee in the pipe up to the drip tubing. The best material to use for risers is a special heavy-wall PVC hose called “IPS hose.” It has the same outside diameter as the equivalent standard pipe size. The advantage of this material is its superior strength and flexibility, which protect it against breakage and mechanical damage above ground. The hose is solvent-cemented like other PVC, but a special deep socket on the tee and special flexible glue are necessary for reliable joints. The top end of the riser has a transition fitting to male garden hose thread for connecting drip tube fittings.

Tubing and Emission Devices. The vast majority of vineyard microirrigation systems use half-inch (nominal inside diameter) tubing and drip emitters. Drip emitters are appropriate in most conditions, but some soils have such poor percolation rates that not all the water from a dripper can infiltrate in one spot. Other sites have very shallow soil that prevents a reasonable volume of soil to be wet from one or two point sources. Such situations may be better served by microsprinklers that wet a larger surface area. Higher evaporative loss, increased weeds, and potential disease problems from wet trunks and higher humidity are factors to consider with micro-sprinklers.

Current practice is to place drip emitters close enough together to create a continuous wetted zone. This usually requires two smaller emitters per vine rather than one larger emitter. In any case, emitters should be located at least a few inches away from trunks to avoid wetting them.

Blocks with more than about 10 feet of elevation change within rows need pressure compensating emission devices to deliver uniform flows. Level terraces and flat blocks are suitable for non-compensating devices, which are less expensive. Drip tube is available with internal emitters preinstalled at standard or custom spacing. Compare total costs of internal versus external emitters. A worker should be able to install 120–150 emitters per hour under good conditions.

Compensating emitters have reasonably constant output within a pressure range of 10–60 psi. Output is nonuniform below 10 psi; above 60 psi is neither safe nor reliable. So, operating within or close to the 20–40 psi range is ideal. Flat blocks can be run at 20–30 psi, depending on row length; higher pressure is needed in longer rows to compensate for additional friction loss. Hillside blocks can start at 15 psi at the top, extending the downhill run within the safe pressure range. Install a pressure-reducing valve midslope at the point downstream flow is 0.1 gallon per minute or greater to keep pressure below from getting too high.

Tube and emission devices need to be reasonably distant from threats such as in-row cultivation, pruning, and harvesting. Tube with drip emitters is typically clipped to a wire around 16 inches above ground. Microsprinklers should be hung to give the desired coverage. Consider the option of connecting small tubing from the emitter to direct the water to the target.

Some people install drip tube stretched fairly tight to the wire. Loose polyethylene tube contracts by perhaps 1.25% or more in the colder temperatures of winter. That may not sound like much, but it equals nearly 5 feet in a 375-foot row. Not allowing slack for that contraction creates a significant stress on fittings and end attachments. Instead, let the tube sag between each vine about a hand width (4 inches) at average vine spacing. Done uniformly, it looks fine. Sloping land requires tubes to be tightly clipped to the wire so they do not work downhill over time.

System Materials

Irrigation systems are mostly made of PVC, notably the basic fittings and pipe in various sizes and wall thickness. PVC is relatively easy to work with and performs well if proper techniques are used. PVC is usually assembled into a single sound structure with solvent-welded (“glued”) joints. Glued PVC valves and fittings, rather than threaded or bolted, reduce labor, leaks, and other trouble. Care must be taken to keep primer and cement off of any moving parts, and be aware that glued joints are permanent. Long runs of buried pipe may be done with gasketed pipe instead of solvent-cemented. Unrestrained gasketed joints push apart under pressure, so trenches must have compacted backfill to prevent movement. Large, high-flow tee and elbow joints need concrete thrust blocking to hold them in place, regardless of type of joints. More complex components may utilize other plastics or metals, typically connected with pipe threads. Larger components tend to use bolted flange or grooved (“Victaulic”) connections.

The PVC pipe sizing system is rather arcane, utilizing pipe “classes” and “schedules,” indicating the

pressure rating and inside diameter/wall thickness. Fittings and pipe outside diameter are consistent among the various materials. Two key design considerations are use of pipe with a margin of pressure capacity for the operating conditions, and use of heavier wall pipe where mechanical damage is possible. Thinner wall pipe is suitable for soft ground or good backfill but is more vulnerable above ground and in rocky soil.

It is foolish to put thousands of dollars of pipe in the ground with joints that leak or blow apart because of poor technique or skimping a few dollars on the proper applicator, primer, or cement. Printed and online information on proper methods of solvent welding is available from PVC cement and fitting manufacturers. An important caution: *do not* put pressurized air or gas in PVC pipe, even for testing. The energy stored in compressed gas can be released in shrapnel if the pipe is damaged or struck. Liquids are incompressible and create little explosive potential beyond water hammer, which can break things.

Summary: The Ideal Work Sequence

Begin with a site evaluation that includes an assessment of the need and possibility for irrigation. Determine the availability of water, flow rate, total volume, and quality. If an irrigated vineyard is feasible, begin vineyard planning and developing the water supply. Do preliminary design, including vine and row spacing, identify block and avenue rough locations, and select pump and filter. Order irrigation materials and, preferably, at least enough trellis to hang drip tube. Install the power, pump, and filter station, and do a final layout. Plan for and trench the underground portion of the irrigation system and install it. Backfill trenches and complete the installation of end posts and line posts for the trellis. Flush the underground system. Depending on conditions, timing, and preference, either install the support wire, drip tube, and emitters now, or plant the vines first. Prepare to inspect, repair, and maintain the system on a regular basis.

References

- Schwankl, L., B. Hanson, and T. Prichard. 1998. *Micro-irrigation of Trees and Vines*. Publication 3378, Division of Agriculture and Natural Resources. University of California, Davis.
- Trimmer, W. L., T. W. Ley, G. Clough, and D. Larsen. 1992. *Chemigation in the Pacific Northwest*. Publication PNW 360, Oregon State University Extension Service, Corvallis.